

Product Data Sheet

Gear Motor 01SJN1

01SJN1 is a DC gear motor with hollow shaft to drive an hex rod (not included). In addition to the compact size and low noise level, it also provides positioning feedbacks using dual Hall effect sensors to support advanced control functions. 01SJN1 is an economical and high quality drive solution, which possesses wide applications.



Feature

- Main applications: Furniture
- Input voltage: 24V DC
- Idle running speed: 66rpm
- Max. torque: 5Nm
- Dual Hall effect sensors positioning feedback
- Mechanical brake
- Hollow shaft: Hexagon 8 mm diameter
- Noise level: ≤ 50 dB
- IP Protection level: IP30
- Color: Black
- Power cord length: 1000 mm
- Cable plug: L3-type minifit 6-pin, 180° plug
- Duty cycle: 10%, max. 2 min. continuous operation in 20 min.
- Ambient operation temperature: 0°C ~ +45°C

Performance Data

Model No.	Drive Torque Max. (Nm)	Typical Speed (rpm)	Typical Current (A) @ 24V DC	
			No Load	Full Load
01SJN1	5	66	1.0	3.5

Current VS. Torque

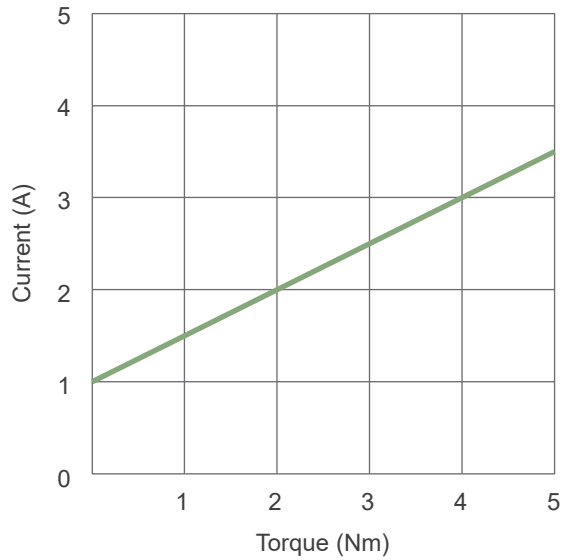

Remarks:

- * The typical speed or typical current means the average value neither upper limit nor lower limit. The performance curves are made with typical values.

Dimensions

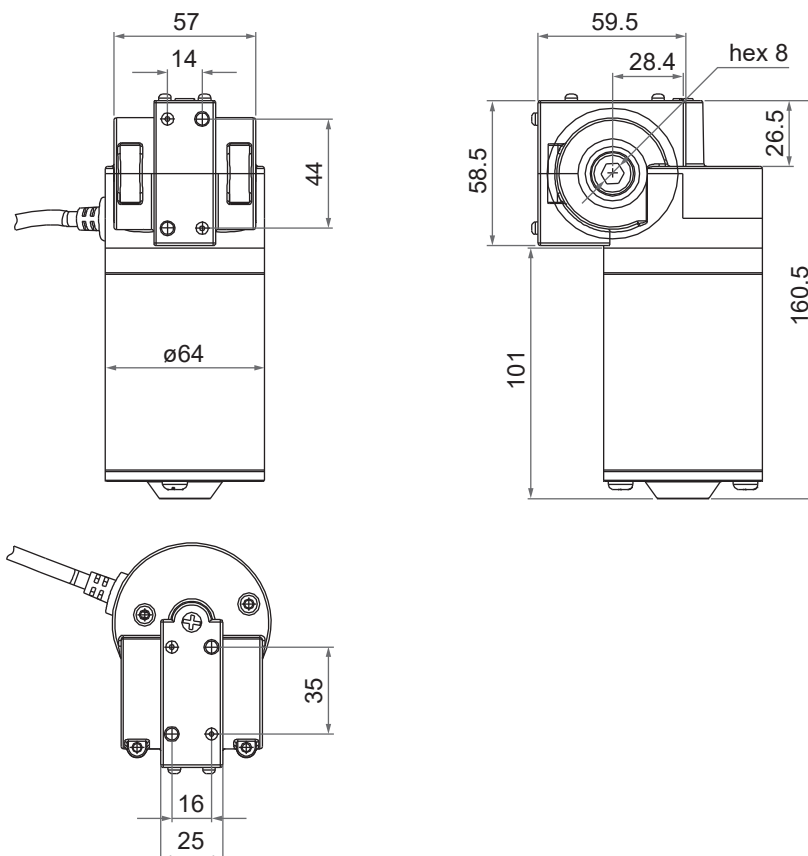

Cable Plug

L3-type minifit 6-pin, 180° plug

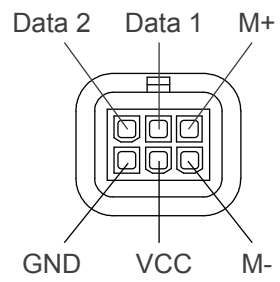

Note

1. Connect Pin (M+) to “+” & Pin (M-) to “-” of DC power, the motor will turn counterclockwise.
2. Dual Hall effect sensors resolution: 16~20 msec/pulse

