

User Guide

Industrial Actuator

Model: 01US10

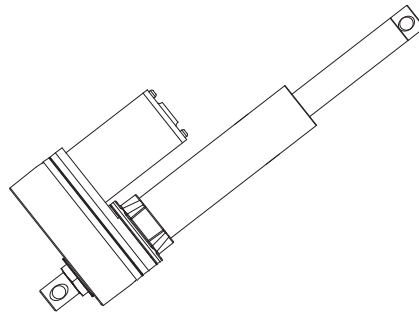

CAUTION

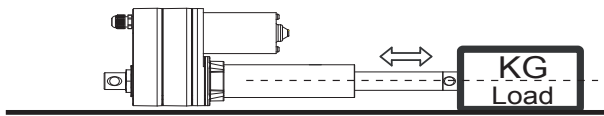

The load should be centered on the operating direction.

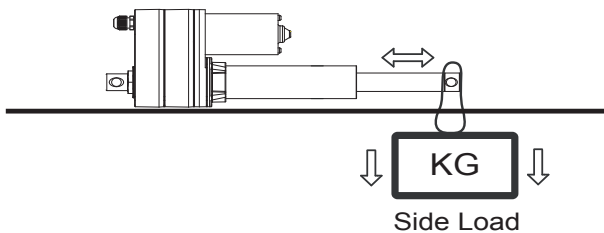

Side load is NOT good for actuators.

MANUAL DRIVE (MD) CONNECTOR

The MD (manual drive) is an alternative way to drive the motor directly, if the power is not available.

- Step 1. Remove the plug on the gearbox cover.
- Step 2. Use a 8.0mm hex bit or electric screwdriver (recommended) to drive the gear directly.
- Step 3. Insert the plug into the hole, and confirm the plug is installed properly.

- The Max. drive torque is 6kg-cm with 4500N load.(Ball Screw)

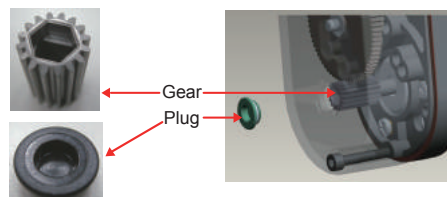

WIRE CONNECTION

For 01US10 actuators, connection rule of power wires varies according to different types and gear ratio(s). Please follow the instructions below.

- Standard Type
 - Please refer to the table below to define the actuator's extension. When Red (M+) is connected to "+" and Black (M-) is connected to "-" of DC power, the actuator will extend.

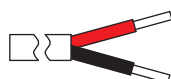

Gear ratio	Power	
	Red	Black
5:1, 10:1, 20:1	M+	M-
30:1, 40:1	M-	M+

With Hall Sensor Type

- Please refer to the table below to define the actuator's extension. When Red (M+) is connected to "+" and Black (M-) is connected to "-" of DC power, the actuator will extend.
- White, Yellow & Blue are positioning signal wires as shown in table.
- The resistance between Blue and Yellow wires increases when extending, and decreases when retracting.
- Signal resolution : 20PPI, 1.27mm/pulse (0.787 pulses/mm)



Power		Signal		
Red	Black	White	Yellow	Blue
M+	M-	VCC	Data	GND

With Limit Switch Type

- Please refer to the table below to define the actuator's extension. When Red (M+) is connected to "+" and Black (M-) is connected to "-" of DC power, the actuator will extend.

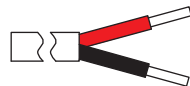

Power	
Red	Black
M+	M-

With Potentiometer Type

- Please refer to the table below to define the actuator's extension. When Red (M+) is connected to "+" and Black (M-) is connected to "-" of DC power, the actuator will extend.
- White, Yellow & Blue are positioning signal wires as shown in table.
- The resistance between Blue and White wires increases when extending, and decreases when retracting.



Power		Signal		
Red	Black	White	Yellow	Blue
M+	M-	GND	VCC	Data

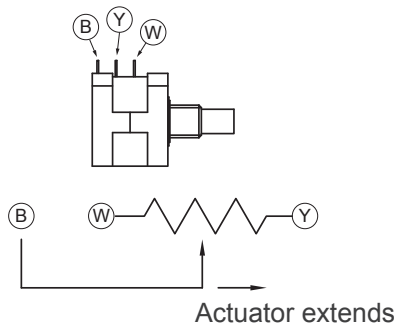

Stroke (mm)	Resistance (tolerance: $\pm 0.3K\Omega$)
102	0.3 ~ 8.1K
153	0.3 ~ 8.7K
203	0.3 ~ 9.2K
254	0.3 ~ 7.4K
305	0.3 ~ 8.8K
457	0.3 ~ 9.4K
610	0.3 ~ 9.8K

SAFETY DECLARATION

This appliance cannot be used by children or persons with reduced physical, sensory or mental capabilities, or lack of experience and knowledge, unless they have been given supervision or instruction.